

CUBOID PATTERN

R0

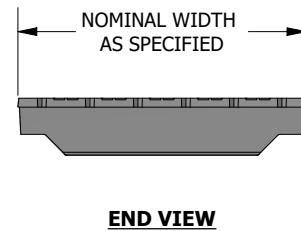
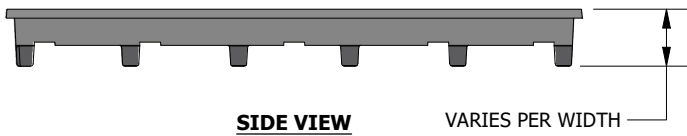
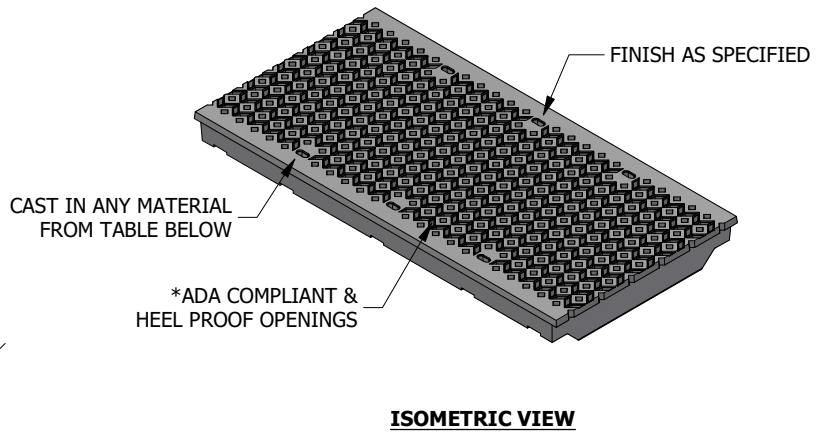
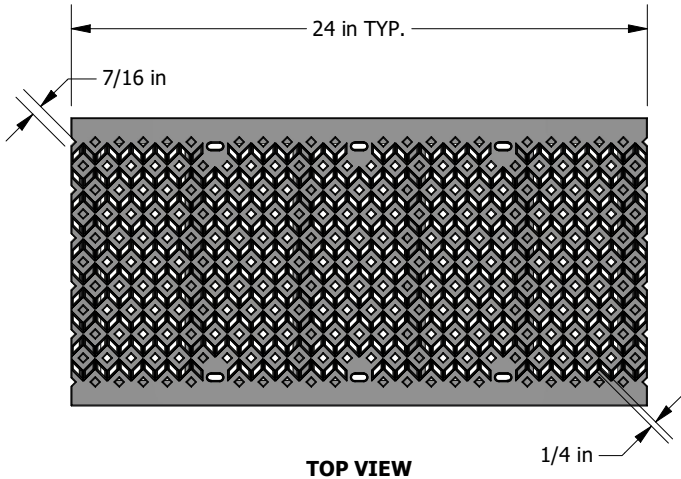
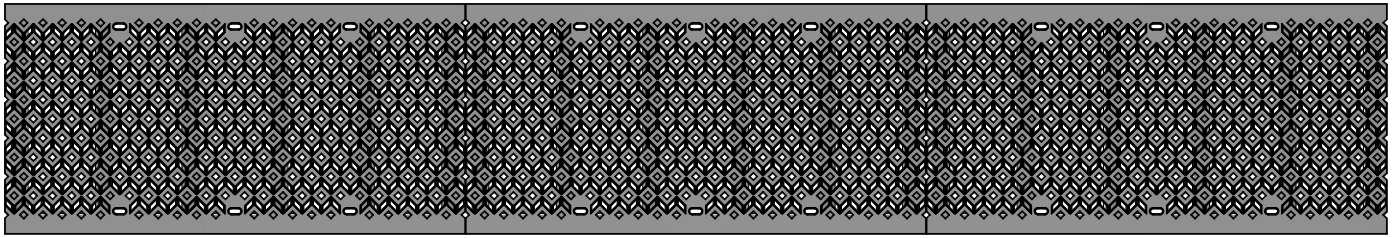

SELECT MATERIAL & FINISH

X	MATERIAL	SELECT MATERIAL & FINISH					
		UNCOATED (NATURAL FINISH)	BLACK POWDER COATED	GALVANIZED	POLISHED	BRUSHED	SANDBLASTED
	DUCTILE IRON				N/A	N/A	N/A
	CARBON STEEL				N/A	N/A	N/A
	STAINLESS		N/A	N/A			
	ALUMINUM		N/A	N/A			
	BRONZE		N/A	N/A			
	BRASS		N/A	N/A			
	POLYMER		N/A	N/A	N/A	N/A	N/A

SELECT NOMINAL WIDTH

	3 in
	5 in
	8 in
	10 in
	12 in
	18 in
	24 in

MATERIAL AS SPECIFIED

FINISH AS SPECIFIED

LOCKING CLIPLOCKS

LOAD RATING DIN CLASS C (OTHERS AVAILABLE PER REQUEST)

ADA / HEEL GUARD NO

STANDARD TOLERANCES

0 = +/-0.25

0.0 = +/-0.25

0.00 = +/- 0.13

DRAWN BY: LRC

*ADA COMPLIANCE DEPENDS ON DIRECTION OF TRAVEL

OPEN AREA: 26.57 SQ IN / LF

WEIGHT: VARIES



296 Industrial Blvd N.
Dallas, GA 30132
PH: 770-505-6575
www.trenchdrain.net